

ISO-VIEW
scale 1:28

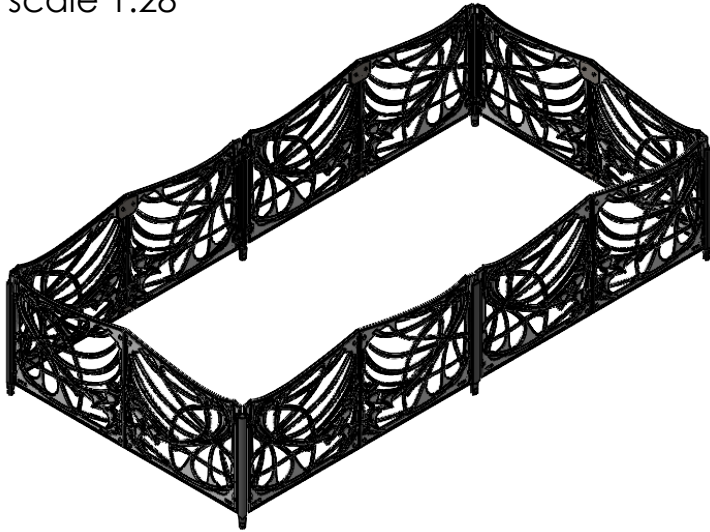

TOP VIEW
scale 1:20

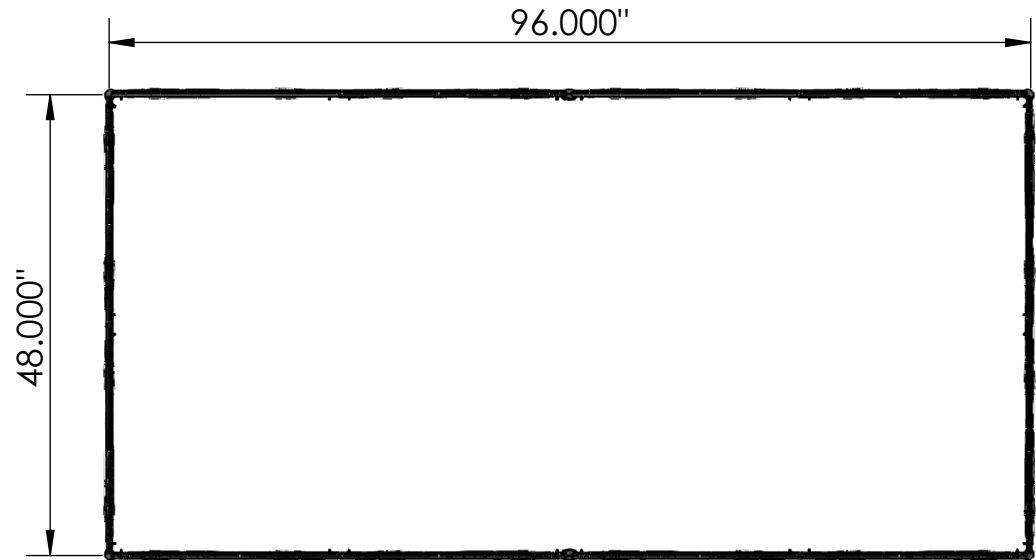

END VIEW
scale 1:20

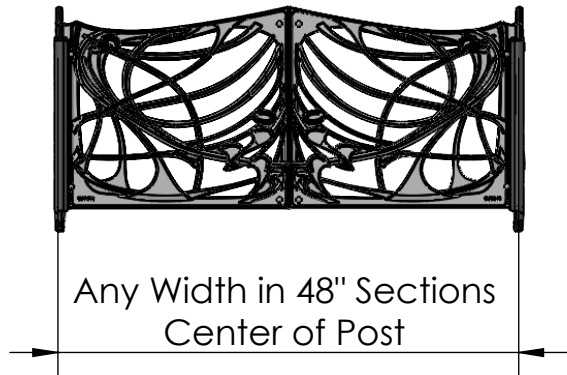

SIDE VIEW
scale 1:20

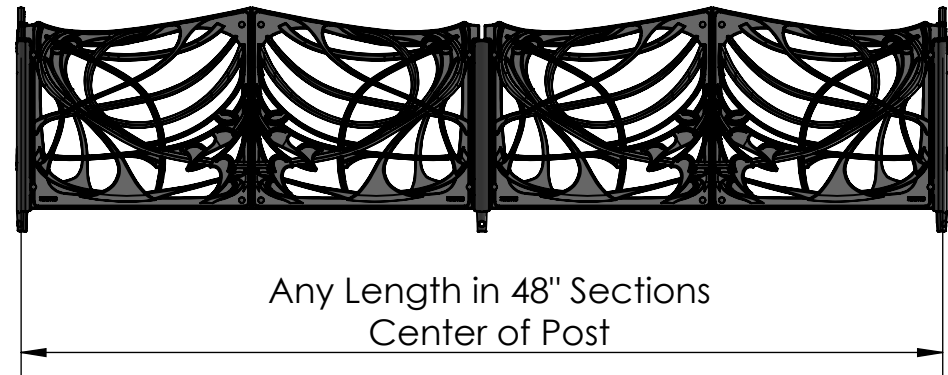

NOTES:

1. Ships in pieces: multiple
2. Due to casting inconsistencies, all dimensions are nominal.

Made in USA ©2019 Iron Age Designs

SF Haight Planter Fence System

 IRON AGE DESIGNS Telephone 206.276.0925 www.ironagegrates.com	Material: Cast Iron / Mild Steel	Weight: N/A lbs.	Free Drain Area: N/A in/sq., or N/A %	By: MS	Checked: MS	Date: 2-23-22
	Finish: TBD	Edge: N/A	Flow Rate: N/A GPM, or N/A CuFt./sec.	© Registration: Pending	Scale: NTS	
	Fits: Landscape by Others	Product ID: NPPF	Drawing Name: 01_SFHaight_PlanterFenceSystem			

TOP-VIEW
scale 1:6

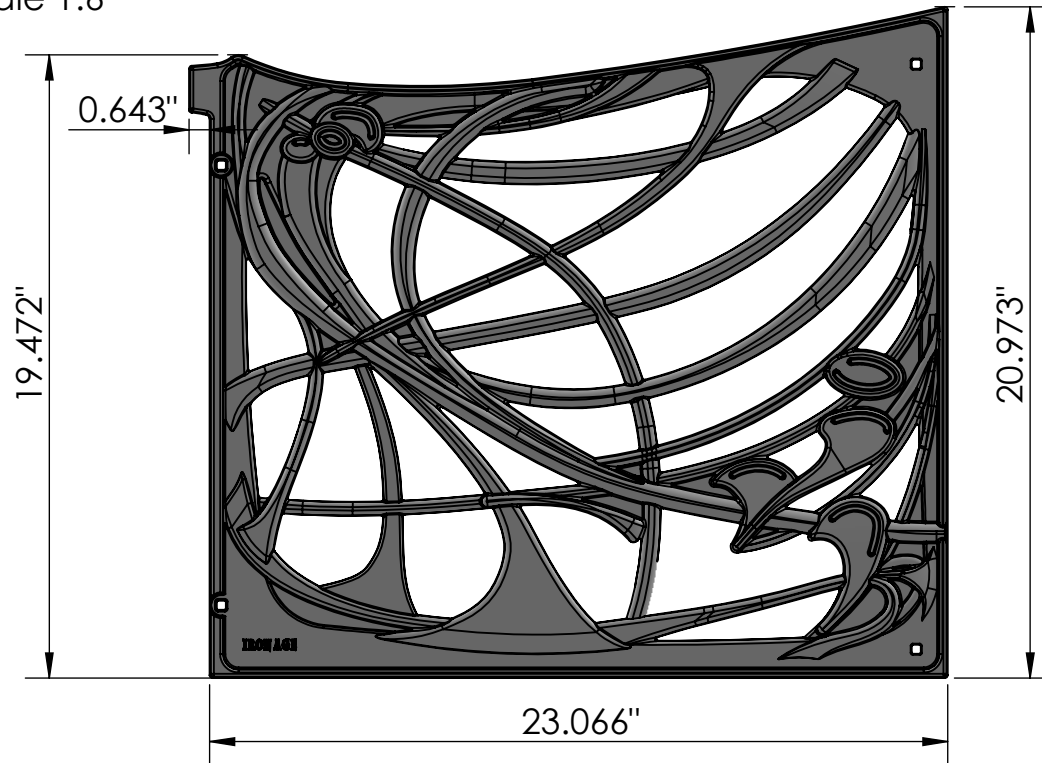

Casting ID
scale 1:1



ISO-VIEW
scale 1:8

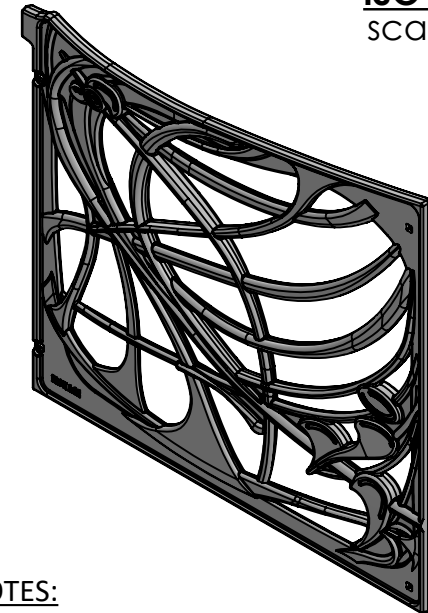

SIDE VIEW
scale 1:6

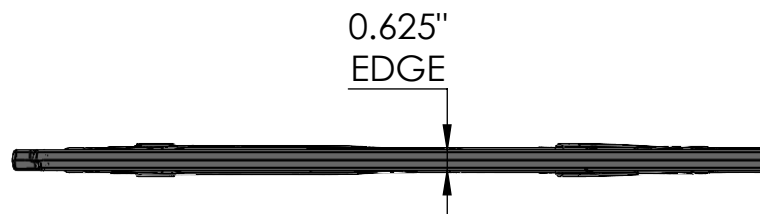

NOTES:

1. Ships in pieces: 1
2. Due to casting inconsistencies, all dimensions are nominal.

Made in USA ©2019 Iron Age Designs

SF Haight Planter Fence System - Left Panel

 IRON AGE DESIGNS Telephone 206.276.0925 www.ironagedesigns.com	Material: Ductile Iron 65-45-12	Weight: 30.65 lbs.	Free Drain Area: N/A in/sq., or N/A %	By: MS Checked: MS Date: 2-23-22
	Finish: TBD	Edge: N/A	Flow Rate: N/A GPM, or N/A CuFt./sec.	© Registration: Pending Scale: NTS
	Fits: SFHaight Planter Fence System	Product ID: NPFLP / NPFRP	Drawing Name: 01_SFHaight_PlanterFenceSystem_LeftPanel	

TOP-VIEW
scale 1:6

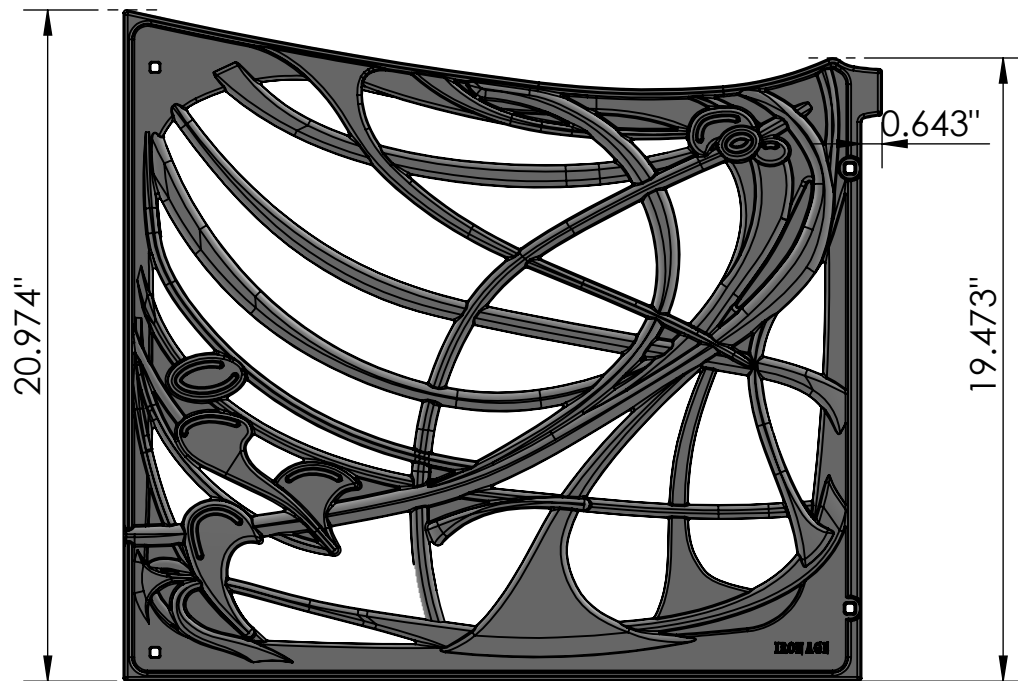

Casting ID
scale 1:1

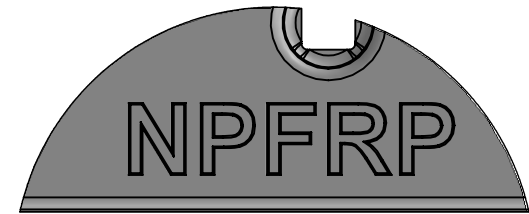

SIDE VIEW
scale 1:6

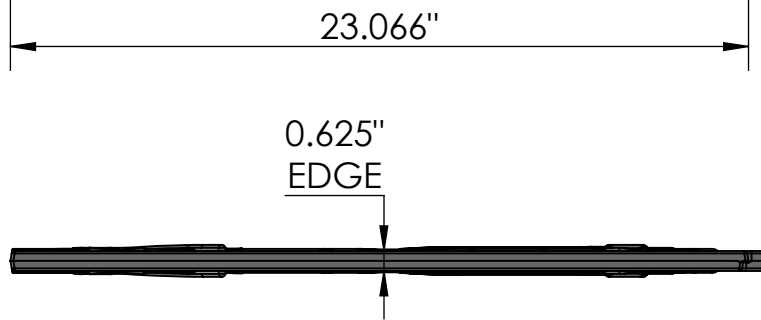

ISO-VIEW
scale 1:8

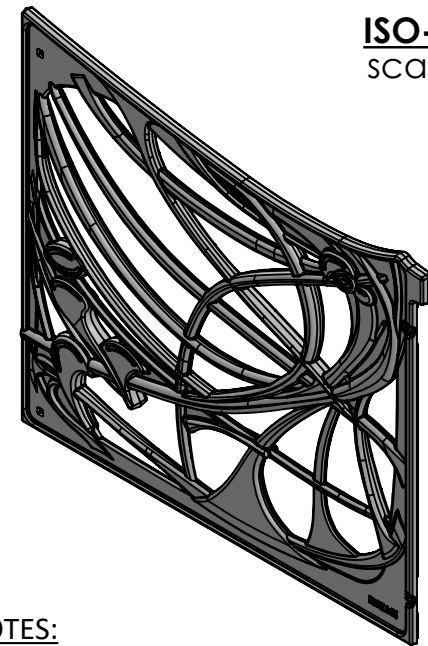

NOTES:

1. Ships in pieces: 1
2. Due to casting inconsistencies, all dimensions are nominal.

Made in USA ©2019 Iron Age Designs

SF Haight Planter Fence System - Right Panel

 IRON AGE DESIGNS Telephone 206.276.0925 www.ironagegrates.com	Material: Ductile Iron 65-45-12	Weight: 30.65 lbs.	Free Drain Area: N/A in/sq., or N/A %	By: MS Checked: MS Date: 2-23-22
	Finish: TBD	Edge: N/A	Flow Rate: N/A GPM, or N/A CuFt./sec.	© Registration: Pending Scale: NTS
	Fits: SFHaight Planter Fence System	Product ID: NPFRP	Drawing Name: 01_SFHaight_PlanterFenceSystem_RightPanel	

ISO-VIEW
scale 1:2

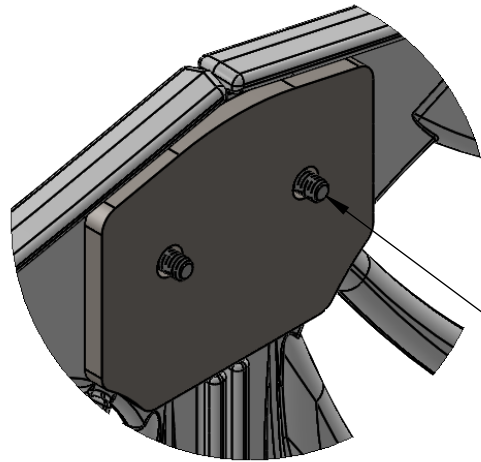

1/4"-20 TYP.
Carriage Bolt
with Washer
and Nut

Ø0.375"
TYP.

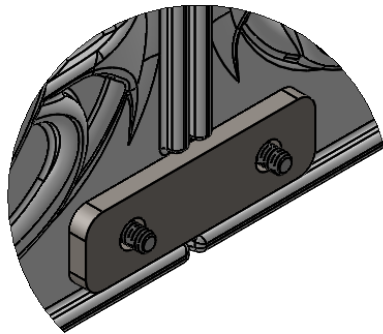

TOP-VIEW
scale 1:1

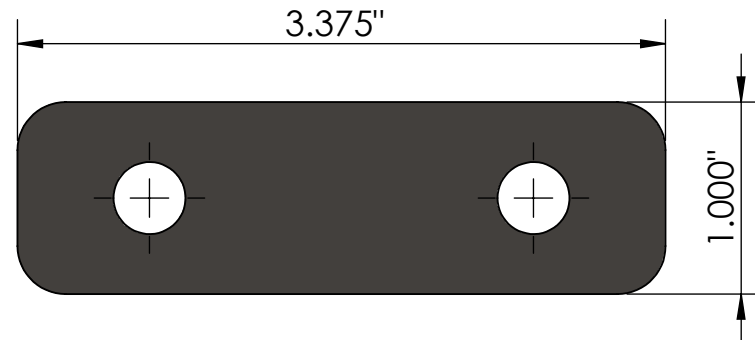
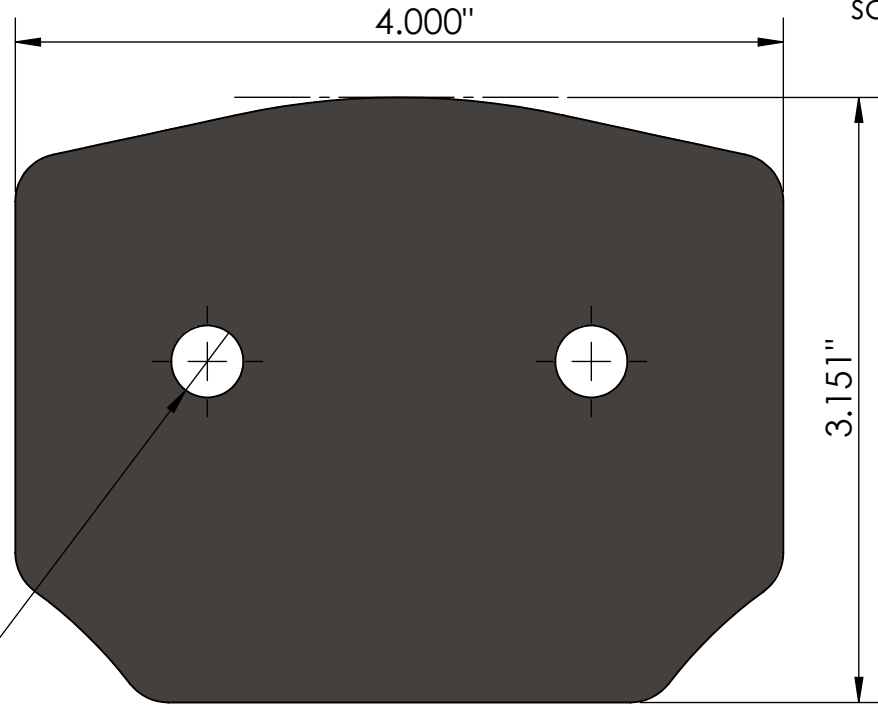

NOTES:

1. Ships in pieces: multiple
2. .250" Mild Steel Material

Made in USA

©2019 Iron Age Designs

SF Haight Planter Fence System - Connectors

 <p>IRON AGE DESIGNS Telephone 206.276.0925 www.ironagegrates.com</p>	Material: Mild Steel	Weight: N/A lbs.	Free Drain Area: N/A in/sq., or N/A %	By: MS	Checked: MS	Date: 2-23-22
	Finish: TBD	Edge: N/A	Flow Rate: N/A GPM, or N/A CuFt./sec.	© Registration: Pending	Scale: NTS	
	Fits: SFHaight Planter Fence System	Product ID: N/A	Drawing Name: 01_SFHaight_PlanterFenceSystem_Top_Bottom_PanelConnector			

Plan-VIEW
scale 1:4

Straight Post
02-A-Post

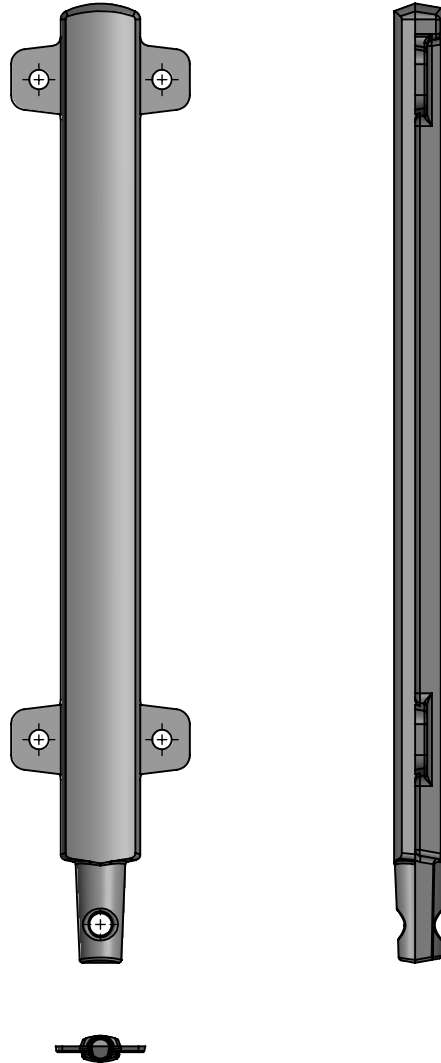

Corner Post
02-B-CornerPost

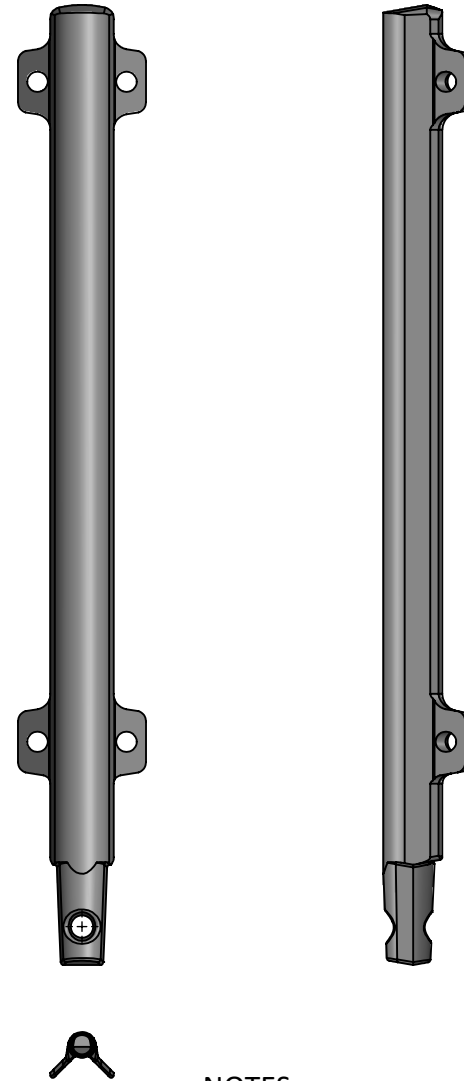

NOTES:

1. Ships in pieces: multiple
2. Due to casting inconsistencies, all dimensions are nominal.

Made in USA ©2019 Iron Age Designs

SF Haight Planter Fence System - Posts

 IRON AGE DESIGNS Telephone 206.276.0925 www.ironagegrates.com	Material: Ductile Iron 65-45-12	Weight: N/A lbs.	Free Drain Area: N/A in/sq., or N/A %	By: MS Checked: MS Date: 2-23-22
	Finish: TBD	Edge: N/A	Flow Rate: N/A GPM, or N/A CuFt./sec.	© Registration: Pending Scale: NTS
	Fits: SFHaight Planter Fence System	Product ID: N/A	Drawing Name: 01_SFHaight_PlanterFenceSystem_Posts	